



Supercritical Fluid Chromatography

Low-Cost, Fast, Green Technology



Low-Cost, Fast, Green Technology

Over the years, JASCO has responded to the growing emphasis on reducing chemical waste by offering an alternative to traditional HPLC with a full line of “green” SFC/SFE products. The reduction in the use of organic solvents has cost, health, and safety benefits as well as faster, cleaner sample recovery during experimental procedures. These advantages are a result of supercritical fluids liquid-like densities offering higher solubility and increased column loading. They have low viscosity and are highly diffuse enabling faster separation and extraction.

The JASCO Advantage

JASCO’s modular SFC/SFE platforms have been optimized and refined over the last 20 years to provide reliable, worry-free performance for a wide variety of applications.

- The patented JASCO back-pressure regulator employs a high-speed switching valve to ensure that a constant back pressure is maintained at all times, regardless of the gas flow rate. Most other systems use a restriction device which is flow dependent and hence is unable to provide the essential constant pressure conditions. The JASCO design has the additional benefit of very low dead volume (below 10 μ L) which prevents fractions from re-mixing. It also presents a significant reduction in any precipitation buildup in the flow line.
- JASCO offers a wide range of detectors with high pressure cells – UV, Diode Array (real-time collection of 3-D spectra and chromatograms), and the only CD detector available for SFC.
- Our analytical SFC/SFE systems can be converted easily to HPLC.
- JASCO’s modifier delivery pumps guarantee stable delivery performance even at high flow rates.
- JASCO offers a truly modular system – from a simple extractor to a complex multi-instrument system that shares the same basic components.
- JASCO SFC systems are compatible with most Mass Spectrometers and offer direct control in both Excalibur and Analyst software.
- JASCO provides professional, fast and courteous support on all of our products. We have 33 different service centers in the U.S. to ensure the highest level of customer satisfaction. Our scheduled and on-site training classes are available for advanced application training.
- JASCO offers multiple configurations, please ask your local sales rep.

Contents

2	Features and Benefits	9-10	Detectors	16-18	Extraction Systems
3	SFC Components	11	Back Pressure Regulators	17-18	Fully Automated Residual Pesticide Extraction Systems
3-4	Carbon Dioxide Pumps	12	Temperature Control Units	19-20	Preparative SFC
5-6	Modifier Delivery Pumps	13	Valves	21	Software
7	Autosampler	14	Vessels	22	Service and Support
8-9	Column Ovens	15	Analytical Systems	23	Training Seminars

Supercritical Fluid Components

Supercritical Carbon Dioxide Pumps PU-2080-CO₂/PU-2086-CO₂/PU-2088-CO₂

Supercritical fluid systems require a pump for transferring liquid carbon dioxide. JASCO offers the PU-2080-CO₂ for analysis applications, the PU-2086-CO₂ for applications ranging from analysis to preparative isolation, and the PU-2088-CO₂ for high-volume, preparative isolation.

PU-2080-CO₂ Supercritical Carbon Dioxide Pump (Analytical Range)

This carbon dioxide transfer pump is for analysis applications. It employs Slow Suction-Quick Delivery (SSQD), recognized for low pulsation as its pumping mechanism, thereby enabling stable transfer. It enables transfer at a stable compositional ratio when using it along with a modifier pump, thereby achieving separation and extraction with high reproducibility. The PU-2080-CO₂ also makes it possible to build an extremely compact analysis system without requiring any external cooling equipment.

PU-2080-CO₂



PU-2086-CO₂



PU-2086-CO₂ Supercritical Carbon Dioxide Pump (Semi-Preparative)

This dual-head supercritical carbon dioxide pump is for applications ranging from analysis to preparative isolation. It employs a specially shaped cam to achieve stable pumping performance up to a high flow rate. A single system can be used to analyze batches and perform purity inspections. It also conserves space by combining the PU-2086 with a compact cooling head.

Supercritical Fluid Components



PU-2088-CO₂

PU-2088-CO₂ Supercritical carbon dioxide pump (Preparative)

This dual-head supercritical carbon dioxide pump is specifically designed for preparative isolation. Due to its ability to transfer carbon dioxide at a stable rate of 10 to 120 mL/min, it can process large volumes of samples up to about 30 mm of column internal diameter for preparative SFC applications and up to 1L of vessel volume for extraction applications.

Model name	PU-2080-CO ₂	PU-2086-CO ₂	PU-2088-CO ₂
Type of pump	SSQD method (Slow Suction-Quick Delivery)		
Flow rate setting	0.001~10 mL/min	0.001~20 mL/min	0.1~150.0 mL/min
Flow rate range	0.2~7 mL/min	0.5~15 mL/min	5.0~120.0 mL/min
Pressure range	0~30 MPa	0~30 MPa (less than 15 mL/min) 0~25 MPa (more than 15 mL/min)	0~30 MPa
Max. pressure	0~35 MPa	0~35 MPa	0~35 MPa
Time programming	Flow rate, Upper pressure limit, Lower pressure limit, solvent switvhing		
Materials	All materilas in contact with solvent are sapphire, ceramic, stainless steel, fluorocarbon polymer, PEEK		
Cooling method	Peltier built-in cooling jacket (circulation bath is required.)		
Dimension	225(W)x430(D)x315(H) mm Approx. 22 kg	150(W)x575(D)x150(H) mm Approx. 11 kg	350(W)x700(D) x260(H) mm Approx. 45 kg
Power input voltage	AC 100~240V, 50/60Hz	AC 100~240V, 50/60Hz	AC 100~120V, 50/60Hz
Power consumption	500VA	185VA	600VA

Delivery capacity at normal flow rate range

Flow rate (mL/min)	0.2	0.5	7	15	120
PU-2080-CO ₂	[Bar chart showing capacity for PU-2080-CO2]				
PU-2086-CO ₂	[Bar chart showing capacity for PU-2086-CO2]				
PU-2088-CO ₂	[Bar chart showing capacity for PU-2088-CO2]				

Modifier Delivery Pumps

PU-2085/PU-2080/PU-2089/PU-2086/PU-2088

Supercritical fluid systems that use carbon dioxide add a modifier solvent when boosting the degree of extraction freedom. Achieving a stabilized compositional ratio (0.1 to 50%) is crucial to performing separation analysis, requiring a pump that performs stable fluid transfer. The PU-2080, PU-2085, PU-2086, PU-2088, and PU-2089 transfer pumps renowned for the use in HPLC, are the optimal choice for pumping modifier solvent.

PU-2085/2080 Semi-micro/Analytical HPLC pump

These pumps are capable of low-pulse pumping due to optimizations of the pump head, check valve, plunger, and other parts, thereby delivering a stable baseline. JASCO's proprietary SSQD pumps deliver co-solvent at a stable rate with low pulsation. The PU-2085 is particularly efficient at pumping in the low flow range. The PU-2085 and PU-2080 are optimal for pumping 0.1 to 3 mL/min and 0.3 to 7 mL/min, respectively.

PU-2085/2080



PU-2089



PU-2089 4-solvent low pressure gradient pump

The PU-2089 is an all-in-one quaternary pump that delivers all the functionality of the PU-2080 HPLC pump, the LG-2080-04 four-solvent low-pressure gradient unit, and the DG-2080-54 four-solvent degasser. The PU-2089 can switch between four different modifier solvents.

Supercritical Fluid Components

PU-2086 Preparative pump

This pump employs a dual plunger system optimal for high-flow pumping. It handles applications up to 20 mL/min and can be used for analyzing preparative samples injected at high volumes. The unit is the same size as the PU-2080 and saves space even when combined with a high-flow pumping system.



PU-2086



PU-2088

Delivery capacity at normal flow rate range

Flow rate (mL/min)	0.1	0.5	7	15	60
PU-2085	[Bar chart showing flow rate range from 0.1 to 3 mL/min]				
PU-2080/2089	[Bar chart showing flow rate range from 0.3 to 7 mL/min]				
PU-2086	[Bar chart showing flow rate range from 1 to 15 mL/min]				
PU-2088	[Bar chart showing flow rate range from 5 to 60 mL/min]				

PU-2088 High-flowrate pump

This unit is a modifier solvent pump developed for preparative SFC. The usual flow rate range is between 5 and 60 mL/min and when used with the PU2088-CO₂ enables the processing of high-volume samples.

Model name	PU-2085	PU-2080	PU-2089	PU-2086	PU-2088
Type of pump	SSQD method (Slow Suction-Quick Delivery)				
Flow rate setting	0.001~4 mL/min	0.001~10 mL/min	0.001~10 mL/min	0.001~20 mL/min	0.1~70 mL/min
Flow rate range	0.1~3 mL/min	0.3~7 mL/min	0.3~7 mL/min	1~15 mL/min	5~60 mL/min
Pressure range	0~30 MPa	0~30 MPa	0~30 MPa	0~30 MPa (less than 15 mL/min) 0~25 MPa (more than 15 mL/min)	0~30 MPa
Max. pressure	0~50 MPa	0~50 MPa	0~50 MPa	0~50 MPa	0~50 MPa
Time programming	Flow rate, Upper pressure limit, Lower pressure limit, solvent switching				
Materials	All materials in contact with solvent are sapphire, ceramic, stainless steel, fluorocarbon polymer, PEEK				
Dimension	150(W)x470(D) x150(H) mm	150(W)x470(D) x150(H) mm	150(W)x470(D) x225(H) mm	150(W)x470(D) x150(H) mm	350(W)x470(D) x260(H) mm
Weight	Approx. 10 kg	Approx. 10 kg	Approx. 14.3 kg	Approx. 10 kg	Approx. 34 kg
Power input voltage	AC 100~240V, 50/60Hz	AC 100~240V, 50/60Hz	AC 100~240V, 50/60Hz	AC 100~240V, 50/60Hz	AC 100~120V, 50/60Hz
Power consumption	185 VA	185 VA	185 VA	185 VA	600VA

Autosampler for SFC AS-2059-SF

The AS-2059-SF autosampler is used to measure multiple-specimen samples.

AS-2059-SF Autosampler

When using supercritical carbon dioxide as a mobile phase, it replaces the content of the sample loop with supercritical carbon dioxide with each injection. Continuous introductions of samples requires the aspiration of the next sample after safely discharging the carbon dioxide in the sample loop and fully replacing it with an organic solvent. The AS-2059-SF can safely discharge carbon dioxide in the sample loop and continuously inject samples. The injection method can be selected as either a fixed injection volume that fills the entire sample loop or a variable injection volume that introduces the sample in a portion of the sample loop. The variable injection volume method is also capable of full injection with zero sample loss.

Temperature Control

The optional sample-warming unit (TC-2059) can control the temperature of a sample between 4°C and 60°C in 1°C increments (temperature control precision: ±1°C).



AS-2059-SF

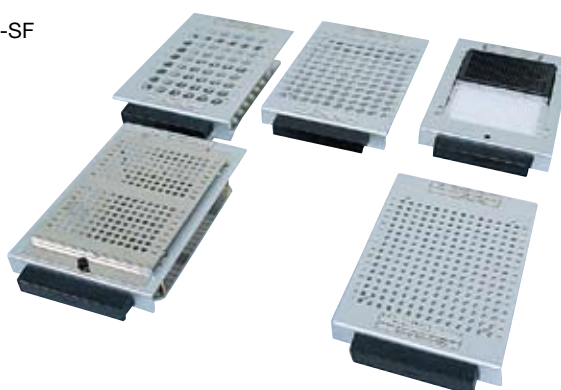

Sample injection method:	Variable sample volume injection method or fixed volume injection method
Number of samples:	120 (2.0 µL vials, standard rack) 54 (Large volume, 4.0 mL vials) 224 (300, 600 µL vials, micro-volume rack) 384 x2 (384-wells microplate X 2, microplate rack)
Sample loop:	5 µL
Injection volume:	0.1 to 100 µL (0.1 µL increments) (Standard, volumes over 10 µL require loop replacement.) 1 to 1000 µL (1.0 µL increments) (Optional, large volume injection kit is required.)
Reproducibility:	RSD 0.5% or less (When fixed loop, 20 µL injection)
Contamination:	0.01% or less (When fixed loop, 5 µL injection)
Injections per vial:	1 to 99
Analysis time setting:	0.1 to 999.9 min (0.1 min increments)
Max. usable pressure:	30 MPa
Temperature setting ranges:	Optional, 4°C to 60°C (Precision : ±1°C)
Materials:	All materials in contact with solvent are ceramic, stainless steel, fluorocarbon polymer, PEEK

Supercritical Fluid Components

Column Ovens CO-2060/CO-2065/SFC-Sro

Density changes due to changes in temperature have a major impact on the separation and extraction process on supercritical fluid systems. Achieving stable extraction efficiency and peak retention times requires the use of an oven to precisely control extraction vessels and regulate column temperature. JASCO offers the CO-2060, which is capable of temperature control at or below room temperature and the CO-2065 and SFC-Sro. The SFC-Sro is designed for temperature control for cup-shaped, high-pressure vessels and it includes a mixing function.



CO-2060



CO-2065

CO-2060/2065 Column Oven

The CO-2060/2065 ovens are capable of temperature control with a precision of $\pm 0.1^\circ\text{C}$ with excellent reproducibility. The CO-2060 is for heating and cooling, while the CO-2065 is for heating only. Both models detect abnormal temperatures and solvent leaks and include a function for shutting off the heat. A manual indicator, preheating coil, reaction coil, and other such devices can be installed on both the CO-2060 and the CO-2065. Furthermore, the CO-2060 can easily perform not only cooling (used for optical isomer separation columns), but also temperature increases and decreases by the use of a time program.

SFC-Sro



SFC-Sro Column Oven

The SFC-Sro oven is capable of heating from room temperatures $+20^\circ\text{C}$ to 150°C and supports not only ordinary columns and extraction vessels, but also cup-shaped, high-pressure vessels. Inserting a mixer enables the efficient mixing of the vessels' contents, improving reaction efficiency within supercritical carbon dioxide.

Model name	CO-2060	CO-2065	SFC-Sro
Temperature control method	Heater, Peltier	Heater	Heater
Temperature control range	15 °C below ambient to 80°C	10°C above ambient to 80°C	20°C above ambient to 150°C
Accuracy	±0.1°C (When temperature is set at 40°C.)	±0.1°C (When temperature is set at 40°C.)	±0.3°C
Stirrer	None	None	Included (100 to 1000 rpm)
Safety check	Heater power shut off when unusually high temperature or flammable solvent leaks are detected.	Heater power shut off when unusually high temperature or flammable solvent leaks are detected.	Heater power shut off when unusually high temperature is detected.
Column compartment	110(W) × 415(H) × 83(D) mm	110(W) × 415(H) × 83(D) mm	240(W) × 245(H) × 200(D) mm
Dimensions	150(W) × 465(H) × 470(D) mm	150(W) × 465(H) × 470(D) mm	310(W) × 460(H) × 460(D) mm
Weight	Approx. 19 kg	Approx. 15 kg	Approx. 20 kg
Power requirements	100~220V, AC, 50/60Hz	100~220V, AC, 50/60Hz	100~120V, AC, 50/60Hz
Power consumption	Approx. 355VA	Approx. 230VA	Approx. 650VA

Detectors

UV-2070/2075/MD-2010/2015/CD-2095

Evaluating optical characteristics under a supercritical state requires a detector and a high-pressure resistant cell. Monitoring samples in supercritical fluid is possible by replacing the flow cell section of JASCO's liquid chromatography detector with a high-pressure resistant cell.

UV-2070/2075 UV/Vis Detector

The UV-2070/2075 UV/Vis detector combines high performance, multifunctionality, and superior operability for most standard detection techniques in chromatography.

UV-2070/2075



MD-2010/2015 Diode Array Detector

Multichannel detectors are currently used in the same manner as general-purpose detectors. The MD-2010 and 2015 deliver high resolution and high sensitivity as a result of an optimized optical system and redesigned data processing circuits. They also can be used as stand-alone detectors, even without a data station. These detectors are equipped with a four-channel analog output terminal. Both time and wavelength accumulation can be set and samples can be measured in the optimal state for the desired sensitivity and resolution.



MD-2010/2015



CD-2095

CD-2095 Circular Dichroism Chiral Detector

This detector measures optical isomers with circular dichromatic absorption between 220 and 420 nm with high sensitivity and excellent selectivity. The CD-2095 is generally 10 to 100 times more sensitive than an optical rotation detector. It can measure both CD and UV chromatograms as well as g-factor (CD/UV) chromatograms. Since g-factor in particular has a proportional relationship with the compositional ratio of optical isomer samples, the CD-2095 can perform compositional measurements and high purity fractionation for non-separated peaks. In addition, spectral measurements for CD and UV are possible by stopped-flow spectrometry.

SFC High Pressure Flow Cells

P/N	Detector	Description
6824-H105A	UV Detector	High pressure flow cell unit, L=5mm, 4uL gasket: PEEK, window: quartz
6824-H118A	UV Detector	High pressure preparative cell unit, L=1mm
6831-H113A	Multi-Channel Detector	High pressure flow cell unit, L=5mm gasket: Pb, window: quartz
6831-H114A	Multi-Channel Detector	High pressure preparative cell unit, L=1mm gasket: PEEK, window: quartz
6838-H106A	CD Detector	High pressure flow cell unit, L=20mm
6838-H107A	CD Detector	High pressure preparative cell unit, L=1mm gasket: PEEK, window: sapphire

Back Pressure Regulators BP-2080/BP-2080-M

Changes in pressure can greatly vary the characteristics of SFC. Achieving extraction and chromatograms with high reproducibility on a supercritical fluid system requires a device that can perform pressure control in a stable manner. JASCO offers the BP-2080, which is capable of automatic pressure control, and the BP-2080-M, which is capable of manual pressure control.

BP-2080/2080-M Back Pressure Regulator

The BP-2080 and BP-2080-M employ a patented flow-switching valve (FSV) mechanism that enables stable system pressure control even at the lowest volume limit possible. The FSV mechanism regulates pressure by controlling the channel opening while a needle vibrates at a high rate of speed. This prevents blockages due to high-viscosity elution samples and solidified samples, which can be a problem with static pressure regulators. This enables stable system pressure, even during long-term continuous operation. Since the BP-2080 has a time program feature that can control pressure and temperature according to the passage of time, it makes it easy to automate analysis work. The BP-2080M offers manual control for the volume passing through the opening in the FSV mechanism.



BP-2080

BP-2080-M

SFC Vch-Bp 6-Way Valve Changer-Fraction Collector

The SFC-Vch-Bp is an option for the BP-2080 that can be attached to the pressure control section of the BP-2080/BP-2080-M. It features a one-channel switching valve and one high-pressure 1-in-6-out valve. This option automatically separates the fluid eluted from the BP-2080 into test tubes or sample bins. The channel switching valve is used for selecting either collection or discharge, while the high-pressure 1-in-6-out valve connects downstream from the channel switching valve to function as 6-way branching valve.



SFC Vch-Bp

Supercritical Fluid Components

Temperature Control Units

HC-2068-01/HE-2068-01-04/CH-201/CCA-1111

Achieving extraction and chromatograms with high reproducibility on a supercritical fluid system requires stable temperature control.

HC-2068-01/HE-2068-01-04 Heater Controller

The HC-2068-01 is a temperature controller for heating supercritical fluid. HE-2068-01 to 04 are heat exchangers that are used in conjunction with the HC-2068-01, and are necessary when performing preparative chromatography and high-volume extraction. These heat exchangers are constructed with stainless steel piping and are used to continuously heat the fluid flowing within the piping. The HE-2068-01 is mainly used for heating fluid before preparative isolation. The HC-2068-02 is primarily used after preparative isolation, while the HC-2068-04 is used to prevent icing at the output of the automatic pressure control valves and to heat samples.



HC-2068-01



HE-2068-01



HE-2068-04

TI-2068-01 Temperature Indicator

The TI-2068-01 is a compact, space-saving temperature indicator. Multiple units can be used simultaneously.



TI-2068-01



Circulating Thermostatic Baths

These units use a variety of circulating thermostatic baths to cool carbon dioxide for the PU-2086-CO₂ and PU-2088-CO₂ as well as to circulate the heat that controls the temperature of the high-pressure vessels.

Valves

HV-2080-01/HV-2080-03/SFC-Evc-Sr/SV-500-8/Safety Valve

JASCO offers a variety of valves available for system upgrades, including automatic valves for channel switching and distributing, stop valves for cutting off channels, and mechanical safety valves for ensuring system safety.

HV-2080-01/hV-2080-03/SFC-Evc-Sr Valve Unit

The HV-2080-01 is a two-channel selection valve, while the HV-2080-03 is a 1-in-6 distributing valve. Both models are high-pressure valves for automatically controlling channel switching. The SFC-Evc-Sr is a high-pressure valve unit that incorporates two 1-in-6-out valves. It is particularly useful in combination with the SCF-Sro for switching between multiple extraction vessels.



HV2080-01



HV-2080-03



SFC-Evc-Sr

SV-500/SV-500-8 Stop Valve

These valves are used to manually open and close the channel. When using carbon dioxide, these valves can stop its supply to the system and make pump conditioning easy by attaching one to the output side of a pump. The valves improve system operability and maintainability.



SV-500



SV-500-8



Safety valve

Supercritical Fluid Vessels

High Pressure Vessels



EV-1



EV-2



EV-3

View Cells

View Cells are capable of extracting samples under a supercritical state via the observation window and monitoring their reaction processes in real time. JASCO offers the SFC-VCI with two windows in the vessel cylinder and the SFC-VCT, which offers three windows that provide a view in the vertical direction as well.



SFC-VC1



SFC-VCT

Supercritical Fluid Analytical

Analytical Supercritical Fluid Chromatography



SFC

The physical characteristics exhibited by supercritical fluid include a diffusion coefficient of dissolved molecules that is a hundred times greater than it is in liquid and a viscosity that is at least one figure smaller. A supercritical fluid chromatography system, which employs such a medium as a mobile phase, can be expected to serve as a separation analysis method that can rapidly perform separation without any drop in separation efficiency, even at fast flow rates, due to a rapid mass transfer inside the column when compared with high-speed liquid chromatography that uses liquid as the mobile phase.

In addition, when carbon dioxide is used as the medium, gasification will occur simply by keeping the separated and fractionated sample at a constant temperature, making this one of the techniques capable of highly efficient refining with few post-processing hassles, such as elimination solvents after preparative isolation. This offers a host of advantages, including cost savings related to the expense of purchasing solvent and discarding organic solvents, and high throughput analysis and preparative isolation due to rapid separation over a short period of time. As a gradient elution technique, SFC is able to vary the three parameters of pressure, temperature, and modifier solvent volume. It can be effectively used when separating oligomers and constituents with differing characteristics. (The temperature gradient requires the use of a column oven that continuously varies temperature over time.)

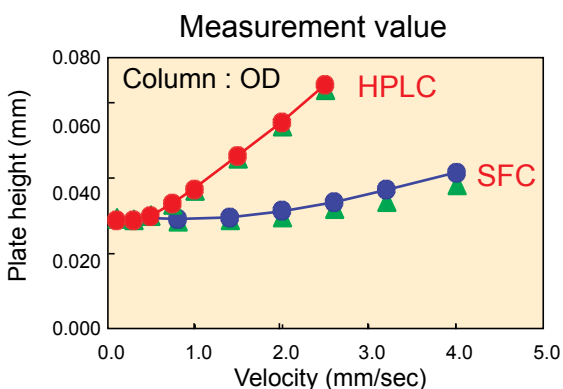

Supercritical Fluid

Supercritical Fluid Extraction (SFE)

Supercritical Fluid Extraction (SFE) Systems

Supercritical fluid extraction (SFE) is a technique that adds a supercritical fluid of an extraction medium to a sample containing a constituent targeted for extraction, using the difference in solubility compared with the extraction medium to carry out the extraction procedure. Using supercritical carbon dioxide as an extraction medium has many advantages and is used in a variety of fields. Extraction by means of supercritical carbon dioxide can be expected to improve efficiency, including shorter extraction times and simplified procedures when compared with extraction techniques that employ organic solvents. In addition, it offers easier solvent elimination and concentration procedures. Since its critical temperature is a low 31°C or so, it enables extraction at a near-room temperature state or in a carbon dioxide atmosphere devoid of oxygen. This makes it a technique that is ideal for materials that exhibit temperature instability or constituents that are susceptible to oxidation. Furthermore, it has received recent attention as an environmentally friendly extraction technique that does not use hazardous organic solvents, as has been advocated by the green chemistry movement in recent years.

Applications for SFE include the extraction of active constituents, including various flavors and medicinal constituents from natural products, docosahexaenoic acid (DHA), advanced unsaturated fatty acids and fatty esters such as eicosapentaenoic acid (EPA), fat-soluble vitamins, and pharmaceuticals. Other applications include the elimination of unwanted constituents, such as decaffeination and desolvation within tablets. It also can be applied to the preprocessing of analysis samples, including HPLC and GC.



Supercritical Fluid Extraction System - Configuration

The figure below shows the basic configuration and flow path of a supercritical carbon dioxide extraction system. In this system, a supercritical carbon dioxide pump, a modifier solvent transfer pump, an extraction vessel, a thermostatic bath, and an automatic back-pressure regulation valve are connected to the downstream end. The extraction vessel can either be a column or cupped vessel, depending on the state of the extraction sample. There is a wide variety of volume types. Extraction parameters include pressure, temperature, and co-solvent/volume. These parameters can be changed to set the optimal conditions.

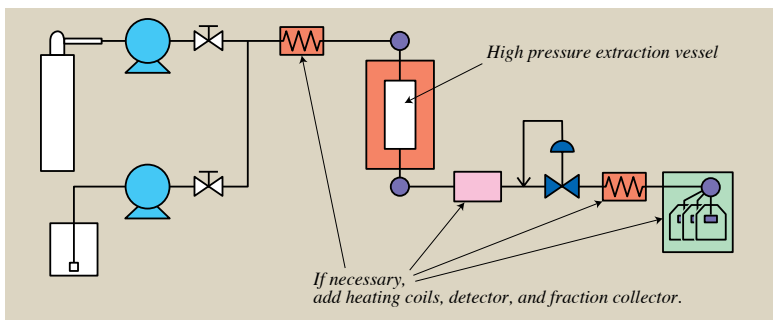

Fully Automated Residual Pesticide Extraction Systems

Residual Pesticide Extraction System 3 (10mL)



Supercritical Fluid

Supercritical Fluid Extraction (SFE)



Residual Pesticide Extraction System 1 (50 mL)

Attention is being focused on extraction techniques using supercritical carbon dioxide for trace pesticides left behind on food products and in soil. Residual pesticide extraction systems that use supercritical carbon dioxide are a topic of interest at present. JASCO has a lineup of residual pesticide extraction systems equipped with these characteristics.

Features

- Simple operation
- Quick extraction - *about 30 to 60 minutes per sample, which is one-third to one-fourth the processing time of conventional techniques*
- Eliminates trace pesticides - *the extract is collected in a trap column*
- Minimal extract cleanup - *also roughly separates impurities in trap column*
- Blockages and contamination are minimized - *the trap column and piping is washed each time*
- Low running costs - *carbon dioxide is highly pure and inexpensive*
- The system is safe and environmentally friendly because carbon dioxide is non-toxic and nonflammable.

Flexibility

- Capacity of extraction vessels: 10 mL or 50 mL. The 10 mL vessel is ideal if operability is the focus. The 50 mL vessel is a better selection if the focus is on sample processing volume or analysis sensitivity.
- The 50 mL vessel offers simple one-touch attachment and removal.
- One to six vessels can be processed at a time. JASCO offers the single vessel type or the six-vessel type depending on the frequency of samples being measured.

Supercritical Fluid

Preparative Supercritical Fluid Chromatography

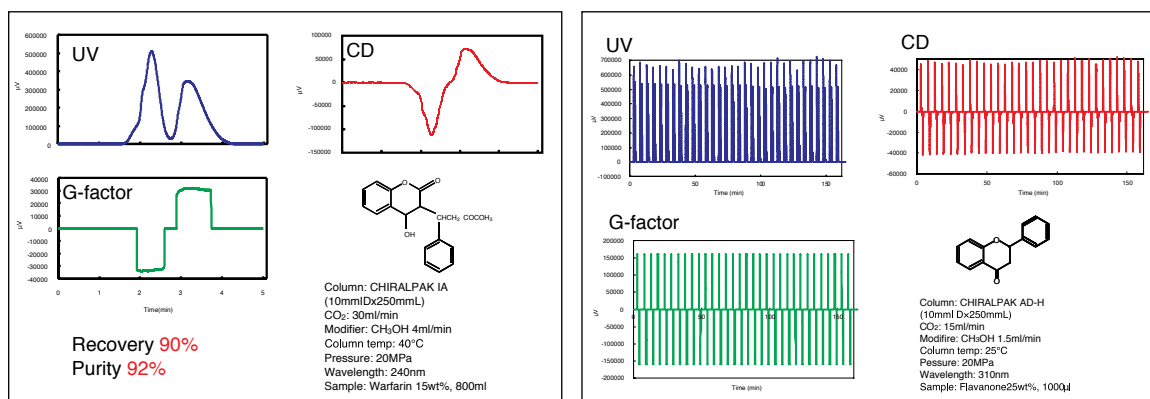

The above photo shows a preparative supercritical fluid chromatography system that scales up the analysis level. The figure to the above left is an example of using an I.D. 10 mm diameter x 250 mm optical separation column on this system, injecting 250 mg of warfarin sample each time, using a circular dichroic (CD) detector for detection, outputting UV and CD at the same time as g-factor, and monitoring the position of the good state of optical purity while isolating with high efficiency. The figure to the above right shows the chromatograms obtained through continuous measurement.

Supercritical Fluid

Preparative Supercritical Fluid Chromatography



The **SF-Box-01** and **SF-Box-02** are used for performing process control for other units. These units are required when using SF-NAV. SF-Box-01 is capable of inputting analog signals and can carry out fraction triggers at detector levels and slopes in preparative SFC. SF-Box-02 is the same as SF-Box-01 without the analog signal input module. It is used mainly for controlling SFE systems.



The **PD-2000** is a distributor for power and signal control and is required when using SF-NAV. The front panel features a large AC switch that can turn on or off system power. It prevents malfunctions by allowing the user to turn system power on/off with a single switch operation which is especially useful on systems comprised of a large number of units. It also plays a crucial role in safe system operation because it can detect system power leakages and over current.

FC-2088-08 Fraction Collector for Preparative SFC

The SF-2088-08 consists of a warming heater placed immediately after the automatic back-pressure valve, a valve for switching between collection and disposal, a fraction control valve, a gas-liquid separator and a collection vial. The setting of valves and temperature is all performed by specially controlled software for supercritical fluid (SF-NAV). With preparative SFC, all devices are installed in a single box, and an exhaust fan maintains decompression. This suppresses the outflow of carbon dioxide and modifier solvent in the lab, thereby enabling preparative isolation in a clean environment.

EZChrom Elite™ **Chromatography Data System for Analytical and Semi-Preparative Systems** Comprehensive Data Analysis

EZChrom *Elite* is a comprehensive software package that can flexibly handle all types of chromatography data requirements and demands. These capabilities range from single-channel to diode-array and spectral data collection modes. Integrated GPC/SEC and system suitability functions are also available. Chromatographers can use EZChrom *Elite* with the confidence that they are using a powerful software package that will meet all of their current and future laboratory data processing needs.

- GLP/GMP features
- Sensible photodiode array data handling
- Fully integrated to control JASCO's SFC/SFE, X-LC® and LC-2000Plus series HPLC systems

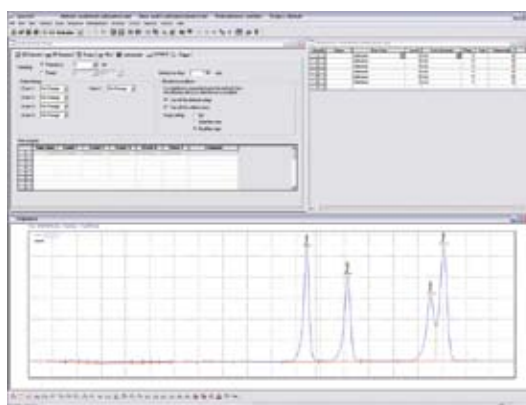

SF-Nav for Preparative SFC

SF-NAV is a specially designed software package for the control and process management of SFE systems and preparative SFC systems. In addition to pumps, autosamplers, and detectors, it can also control automatic back-pressure valves and fractionation. It can monitor and save information such as temperature, pressure, and CO₂ flow within the system during preparative isolation and the extraction process, making it useful when investigating fractionation and extraction conditions. It can also set fractionation and extraction conditions in line with the slope and threshold values of signals obtained from detectors and other devices. It enables full process automation for preparative isolation and extraction. The program can list the operation state of units, show icons that invoke processes by sample, and displays a monitor screen for chromatograms. It can also batch-save parameters including chromatograms, temperature, pressure, and CO₂ flow and export them in ASCII format.

The operational state of the equipment modules and any abnormalities can be seen on the display. In addition, the display shows the temperature and pressure necessary for process management on a supercritical fluid system, including analog signals from detectors and other devices. The remaining volume in the gas cylinders is displayed based on the volume of CO₂ consumed, as calculated according to flow settings.

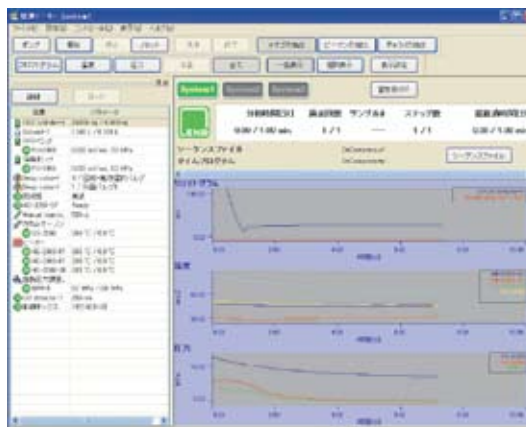

Service and Support

Committed to Service Excellence

JASCO offers world class service and support. Once an instrument is purchased, JASCO's commitment to you is just beginning. We offer a multitude of services and programs that will keep your equipment operating at peak performance.

Choose the plan that is right for you. We offer four plans to make sure we have one that fits both your budget and requirements.

Advantage Support

The Advantage Support plan offers the ultimate coverage and includes:

- All parts, labor and travel costs
- Two Preventative Maintenance (PM) calls per year
- One IQ/OQ service
- One free customer training class at Jasco, Inc.
- Unlimited phone support for technical and application issues
- 20% discount on consumable parts

Full Support

The Full Support plan offers excellent coverage at a very reasonable cost to ensure your instrument is always in optimum running condition. This plan includes:

- All parts, labor and travel costs, excluding consumables
- Customized one or two Preventative Maintenance (PM) calls per year
- Discounted IQ/OQ service (performed at the same time as PM)
- One free customer training class at Jasco, Inc.
- Unlimited phone support for technical and application issues
- 15% discount on consumable parts

Preventative Maintenance Support

- One Preventative Maintenance call per year
- Unlimited phone support for technical and application issues
- 5% discount on consumable parts

JASCO offers over 30 service centers strategically located around the busiest customer-based areas in North America to better serve our customers.

JASCO guarantees parts availability and support for 10 years after purchase date of any SFC system or components.

Application Training Seminars

Quality Training from Jasco, Inc.

Increasing productivity in the lab requires reliable instruments, quality support and a strong working knowledge of the instrumentation. JASCO training seminars are specifically designed to increase your knowledge of JASCO products and related applications, as well as instrument maintenance and troubleshooting procedures.

We offer both on-site training and regularly scheduled training seminars at our Easton, Maryland applications lab. For more information regarding pricing, times and course schedules, or regarding on-site training at your facility please contact us at 800-333-5272.

Our seminars include: Circular Dichroism J-Series, FT-IR Spectroscopy, Fluorescence, UV-Vis/NIR, Polarimetry, HPLC, X-LC®, and Supercritical Fluid Chromatography.

The hands-on aspect of JASCO's programs, combined with small class sizes, ensure that you receive the optimum learning experience.





JASCO INTERNATIONAL CO., LTD.

4-21, Sennin-cho 2-chome, Hachioji, Tokyo 193-0835, Japan

Tel: +81-42-666-1322 Fax: +81-42-665-6512

www.jascoint.co.jp

Australia, China, Hong Kong, India, Indonesia, Iran, Korea, Malaysia, New Zealand, Pakistan, Philippines, Russia, Singapore, South Africa, Taiwan, Thailand

JASCO INCORPORATED

28600 Mary's Court, Easton, MD 21601, U.S.A

Tel:+1-800-333-5272 Tel:+1-410-822-1220 Fax:+1-410-822-7526

www.jascoinc.com

Canada, Costa Rica, Mexico, Puerto Rico, Argentina, Brazil, Chile, Colombia, Paraguay, Peru, Uruguay

JASCO EUROPE s.r.l.

Via Confalonieri 25, 23894 Cremella (Lc), Italy

Tel: +39-039-956439 Fax: +39-039-958642 www.jasco-europe.com

JASCO Deutschland www.jasco.de, JASCO UK www.jasco.co.uk, JASCO France

www.jascofrance.fr, JASCO Benelux www.jasco.nl, JASCO Spain www.jasco-spain.com,

JASCO Scandinavia www.jascoscandinavia.se, Austria, Finland, Greece, Hungary, Poland,

Portugal, Romania, Switzerland, Algeria, Cyprus, Egypt, Israel, Jordan, Kuwait, Lebanon,

Morocco, Saudi Arabia, Syria, Tunisia, Turkey, U.A.E.