

# Dedicated dissolution testing software for complete system control and real-time monitoring

## Full system control and real-time monitoring

The DT-810 dissolution tester is controlled by a 21 CFR 11 compliant software package. The dedicated software offers simple operations for fully automated control and monitoring of the whole system including the pump, fraction collector and the UV-Vis spectrophotometer. Powerful and user-friendly features include a validation support program compliant with USP, EP and JP procedures; monitoring of system status such as the bath temperature, vessel temperatures and the UV-Vis absorbance values for samples, among other parameters.

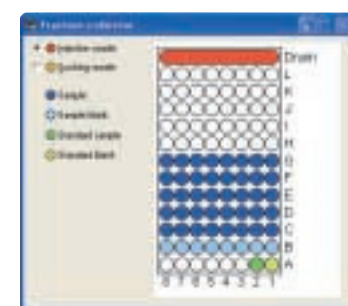
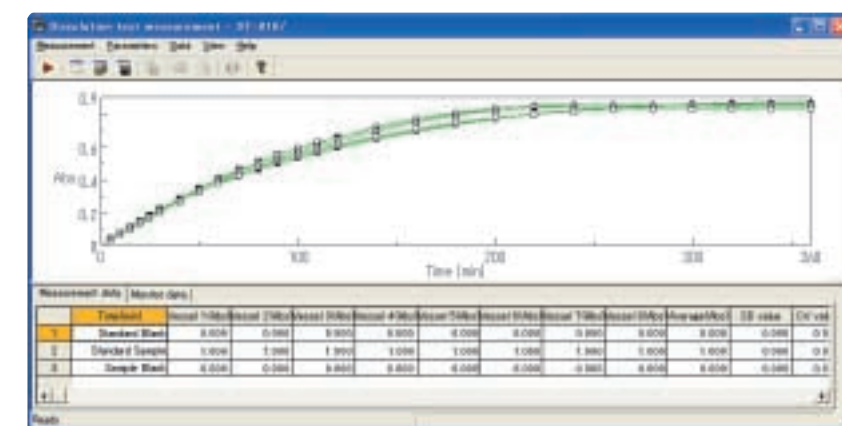

### ● Status of the test tube rack

When using the FC-812AS, the sample test tube status is displayed using different colors. Sampling nozzle position can be controlled through the window to deliver samples to the UV-Vis spectrophotometer.

### ● Measurement window

The standard monitor window displays the sample absorbance or dissolution curves in addition to a table of absorbance values for each sample line. During testing, the monitor window also outlines the system status including the bath temperature, vessel temperature (option) and spindle speed, etc. while parameters such as the auto-save settings and/or the printing mode can be selected.

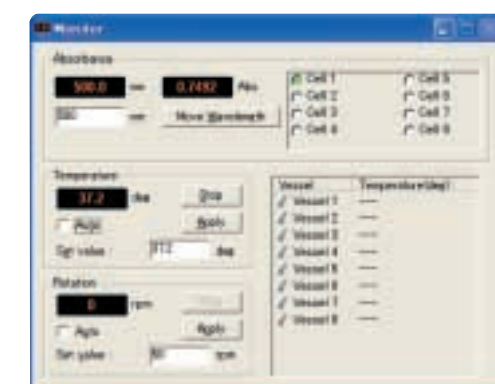

### ● Monitor spindle speed and vessel temperature

Spindle rotation speed, bath temperature and the temperature of dissolution vessels can be readily monitored. (Optional sensors can be supplied to monitor dissolution vessel temperature.) The results of spindle rotation speed and vessel temperature are automatically recorded during dissolution tests. For the Flow System, the UV-Vis monitor window can be used to check washing status of the 8-position flow cells. Systems which include the UV-Vis spectrophotometer also automatically save the dissolution rates in addition to the spindle rotation speed and bath temperature.

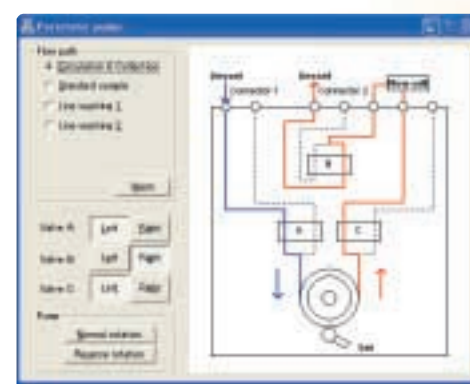

### ● Monitor sample flow lines

The current status of sample flow lines and the peristaltic pump is displayed. This window also provides selection of the pump switching valves and control of the pump flow direction.

## DT-810 specifications

Number of vessels	8 vessels, 1000 mL each
Spindles	Test method: Paddle method (Standard) Rotating basket method (Optional) Rotation speed of spindle 5 to 300 rpm Accuracy of rotation speed of spindle: ± 1 % Drive System :stepping motor
Thermostatted bath	Circular bath design with rotating function Stirring: Magnetic stirrer Temperature control: circular heating element Temperature range: 32-45 °C (25 °C room temperature) Temperature accuracy: ± 0.1 °C (32-45 °C) Temperature stability: ± 0.05 °C (32-45 °C) Temperature accuracy (dissolution vessels): ± 0.1 °C (32-45 °C) Safety: Overheating protection using float switch, limit controller, temperature sensor Drain port for quick and simple cleaning
Sample ports	Automated lifting and lowering by stepping motor User declared automatic sampling Sampling position: automated by method parameters and solution volume
Dosage loading	Automatic (tablets, capsules, test sinker)
Vessel centering	Direct-Center™ automated mechanism
Temperature sensor position	Vessel water bath, dissolution vessels (optional)
Power requirements	100, 115, 200, 220, 230, 240 V; 50/60 Hz; 1100 VA (including LH-PV)
Dimensions	565(W) x 720(D) x 670(H) mm
Weight	Approx. 90 Kg (main unit including vessels and paddles; without water)

## Software specifications

Functions	System control and monitoring, data collection, data analysis DT-810: bath temperature, drive shaft rotation speed, sample flow, dissolution vessel temperature (optional)
Monitoring items	Liquid handling unit: Autosampler position Fraction collector: Current sample status V-530: Absorbance value of specified cells

## Liquid handling unit specifications

Model	LH-PV2	LH-PV3
Number of sample lines	8	8
Solvent supply procedure	8-line peristaltic pump	8-line peristaltic pump
Tubing	PharMed® tubing	PharMed® tubing
Roller	stepping motor, normal and reverse flow	stepping motor, normal and reverse flow
Sampling accuracy	3% (when sampling 20 mL)	3% (when sampling 20 mL)
Switching valve	2 valves	3 valves
Dimensions	160 (W) X 352 (D) X 311(H) mm	160 (W) X 352 (D) X 395 (H) mm
Weight	12 Kg	13 Kg

## Fraction collector specifications

Model	FC-812AS
Sampling procedure	8-nozzle filling mechanism
Sampling system	Freely moving X, Y, Z axis positioning
Fraction collection	96 positions (20 mL test tubes)
Maximum sampling volume	20 mL
Minimum sampling interval	Sequence: 4 minutes (parameter dependent) sampling: 1 minute for first sample, 2 minutes minimum thereafter (parameter dependent)
Contaminant free enclosure	Supplied as standard
Power requirements	100, 115, 200, 220, 230, 240 V; 50/60 Hz; 50 VA
Dimensions	300 (W) X 496 (D) X 415 (H) mm
Weight	23 Kg (main unit and sample rack)

## 8-position flow cell specifications

Model	TQ-801
Cell(option)	8: 10 mm path length flow cells 5, 2 and 1 mm path length flow cells (optional)
Reference position	single cell holder (10 mm cuvette)



● Specifications are subject to change without notice.

## JASCO INTERNATIONAL CO., LTD.

4-21, Sennin-cho 2-chome, Hachioji, Tokyo 193-0835, Japan  
Tel: +81-426-66-1322 Fax: +81-426-65-6512 Internet: <http://www.jascoint.co.jp/english/index.html>  
Australia, China, Hong Kong, India, Indonesia, Iran, Korea, Malaysia, New Zealand, Pakistan, Philippines, Russia, Singapore, South Africa, Taiwan, Thailand

## JASCO INCORPORATED

8649 Commerce Drive, Easton, Maryland 21601-9903, U.S.A  
Tel: +1-800-333-5272 Tel: +1-410-822-1220 Fax: +1-410-822-7526 Internet: <http://www.jascoinc.com>  
Canada, Costa Rica, Mexico, Puerto Rico, Argentina, Brazil, Chile, Colombia, Paraguay, Peru, Uruguay

## JASCO EUROPE s.r.l.

Via Confalonieri 25, 23894 Cremella (Lc), Italy  
Tel: +39-039-956439 Fax: +39-039-958642 [www.jasco-europe.com](http://www.jasco-europe.com)  
JASCO Deutschland [www.jasco.de](http://www.jasco.de), JASCO UK [www.jasco.co.uk](http://www.jasco.co.uk), JASCO France [www.jascofrance.fr](http://www.jascofrance.fr),  
JASCO Benelux [www.jasco.nl](http://www.jasco.nl), JASCO Spain [www.jasco-spain.com](http://www.jasco-spain.com), JASCO Scandinavia [www.jascoscandinavia.se](http://www.jascoscandinavia.se)  
Austria, Finland, Greece, Hungary, Poland, Portugal, Romania, Switzerland, Algeria, Cyprus,  
Egypt, Israel, Jordan, Kuwait, Lebanon, Morocco, Saudi Arabia, Syria, Tunisia, Turkey, U.A.E.



Serving the global marketplace with Analytical Instrumentation  
JASCO Corporation  
2861-5, Bunkyo-cho, Hachioji, Tokyo 193-0837, Japan  
<http://www.jasco.co.jp>  
JIDT-0511 Printed in Japan

# DT-810 Dissolution Tester

Excellent reliability and stability  
to comply with USP, EP and other pharmacopeia

Highly flexible  
Fully automated  
Innovative software



## Circular bath design for optimum temperature uniformity



The model DT-810 Dissolution Tester is fully automated and designed for flexibility to provide dissolution testing of up to 8 samples with either the paddle method (standard) or the rotating basket method (option). The unique circular design provides uniform water temperature while utilizing a round heating element. The Direct-Center™ automatic centering mechanism provides hands-free positioning of the dissolution vessels and drive shafts for accurate dissolution tests with high reproducibility. All components can be controlled via PC using simple keystroke operations with a user friendly graphic interface.

- Meets USP, EP and JP requirements
- 21 CFR Part 11 compliant
- Excellent temperature stability using the circular bath
- Uniform temperature distribution between vessels
- Easy to set up and maintain
- Direct-Center™ vessel centering for automatic alignment of vessels and drive shafts
- Test vessels manufactured with precise tolerances for vessel dimensions
- PC control for monitoring
- Automated tablet dropping system for dosage loading
- Automatic sampling tube positioning for upper and lower positions



## Flow System

### Continuous photometric analysis during dissolution

This system integrates the DT-810 with an 8 position flow-cell accessory and a UV-Vis spectrophotometer. A peristaltic pump (LH-PV2) continuously circulates sample solution between the 8 dissolution vessels and the flow cell accessory. Absorbance values are measured at user declared intervals and dissolution rates are automatically calculated. External samples can also be introduced for analysis.

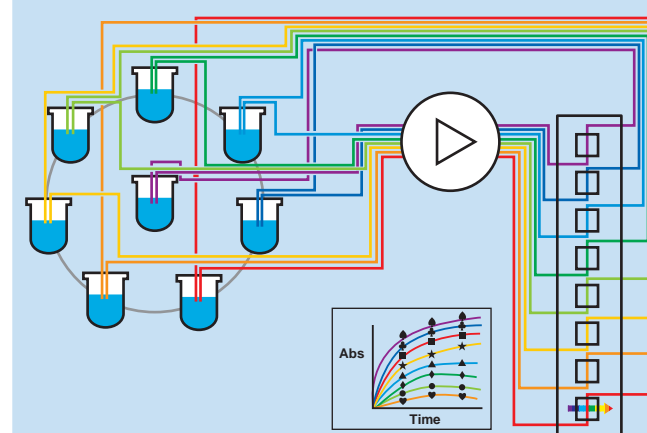
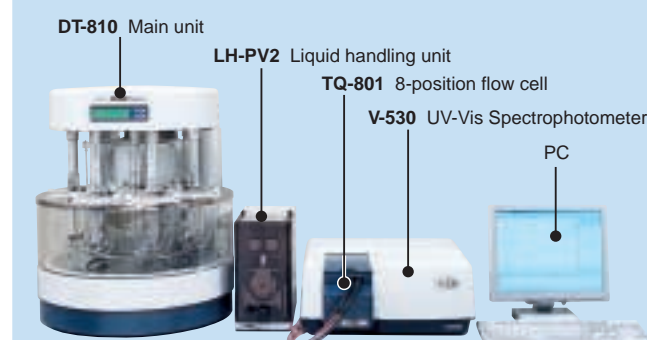

## Fraction System

### Analyze a maximum of 12 sets of 8 samples

This system integrates a fraction collector and the LH-PV3 pumping unit for off-line testing. As many as 12 sets of samples with a volume of 20 mL or less can be collected from each dissolution vessel at pre-set intervals. Additional flow lines for solvent refills or line flushes using internal or external volumes are available.

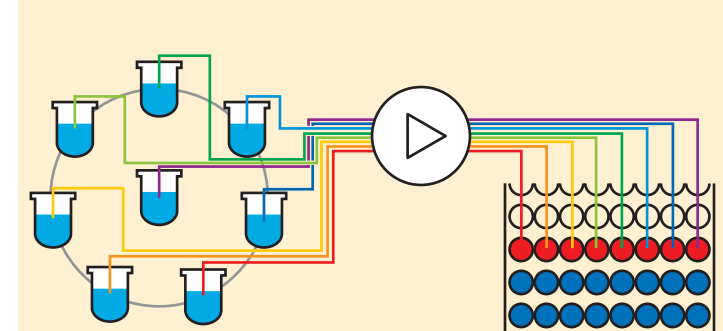
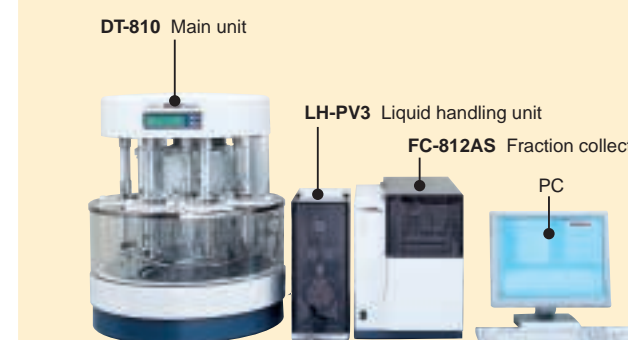

## Fraction Flow System

### Flexibility for on-line and/or off-line testing

This system combines the fraction collector and a flow cell installed in a UV-Vis spectrophotometer. Samples from the dissolution vessels are collected in test tubes using the fraction collector and sample aliquots are analyzed by the UV-Vis using the autosampling capability of the fraction collector. Residual sample volumes can be analyzed later using other techniques such as HPLC.

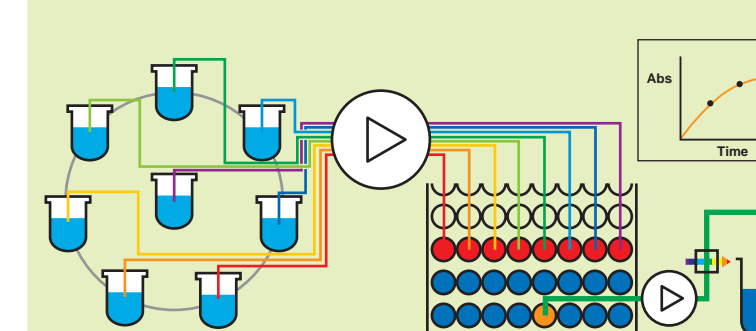
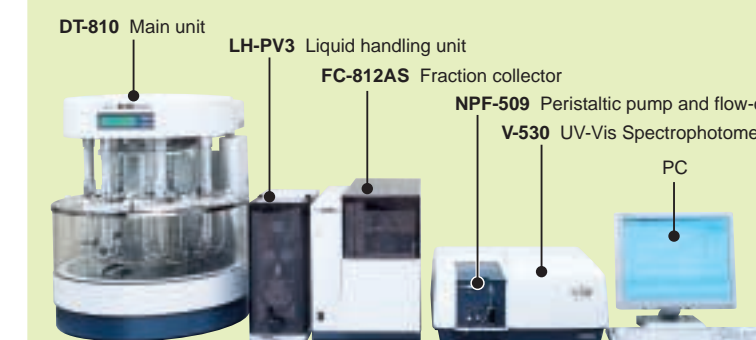

## LH-PV series Liquid handling unit (peristaltic pumps)



The LH-PV series are 8-channel peristaltic pumps for sampling or circulation of sample solutions with adjustable flow rates.

### •LH-PV2 (Flow System only)

Designed for the Flow System configuration, the LH-PV2 circulates sample solution between the dissolution vessels and the 8-position flow cell. Extra flow lines can be used to introduce external solutions and/or for line flushing to reduce sample carryover.

### •LH-PV3 (for all systems)

The LH-PV3 can be used for both sample collection and sample circulation. Additional flow lines are available for solvent refill, introduction of standard solution and/or line flushing using an external source or a selected dissolution vessel.

## Fraction collector



### •FC-812AS

Using up to 96 test tubes, the FC-812AS Fraction Collector can simultaneously collect a maximum of 12 separate samples from each of the eight dissolution vessels. When coupled with the NPF-509 peristaltic pump, the FC-812AS can also deliver sample aliquots to a UV-Vis instrument using the integrated autosampler function.

## UV-Vis spectrophotometer



### •V-530 UV-Vis spectrophotometer

The V-530 is a flexible UV-Vis spectrophotometer suitable for dissolution sample testing. The Flow System combines the TQ-801 8-position flow cell accessory with the V-530 spectrophotometer. The Fraction Flow System utilizes the NPF-509 peristaltic pump and integrated flow cell with the V-530 for sample analysis. The V-530 is supplied with validation support software for instrument performance tests. (Note: optional standards are required for instrument validation.)

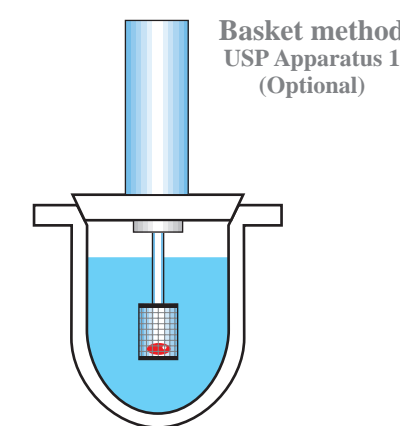
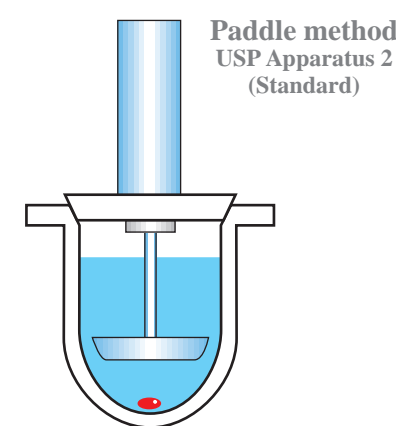

The DT-810 is designed for use with USP Apparatus 1 and 2.

